

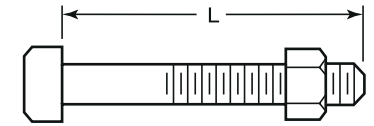

HGA

**Brida Roscadas (Threaded) Acero Inoxidable
304L / 316L ANSI B16.5 RF NPT ASME B1.20.1 Clase 150**

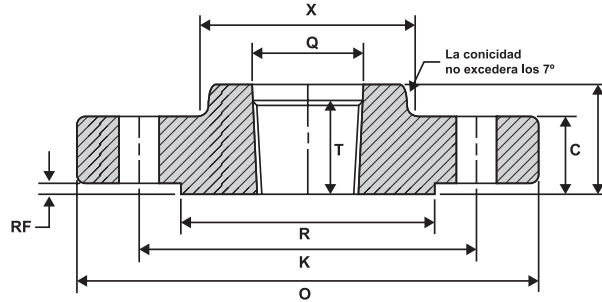

Perno con tuerca

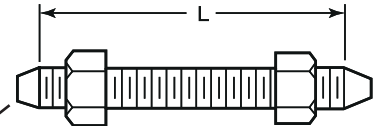

Hilo corrido con tuerca

Alto de punto
(Nota 1)

Unidades en mm

EDICIONES MAC - MMAX

Medida Nominal (pulg) (mm)	Dia. Exterior de Brida (O)	Espesor de Brida (C)	Dia. del Eje a la Base (X)	Dia. del Eje a los Agujeros (K)	Largo a través de Eje (Y)	Raised Face (RF)	Dia. de Raised Face (R)	Dia. de Agujero (Q)	Alto de Rosca (T)	Dia. Agujeros	Núm. de Agujeros	Kgs. Aprox.	Dia. de Pernos		Largo de Pernos (L)			
													pulg.	mm	2mm Raised Face	Ring Joint	2mm Raised Face	
1/2"	12	88.9	11.1	30.2	60.4	15.7	1.5	35.0	22.3	15.7	15.7	4	0.4	1/2	13	55	...	50
3/4"	18	98.5	12.7	38.1	69.8	15.7	1.5	42.9	27.6	15.7	15.7	4	0.7	1/2	13	65	...	50
1"	25	107.9	14.2	49.2	79.2	17.5	1.5	50.8	34.5	17.5	15.7	4	0.9	1/2	13	65	75	55
1 1/4"	31	117.3	15.7	58.6	88.9	20.5	1.5	63.5	43.1	20.5	15.7	4	1.2	1/2	13	70	85	55
1 1/2"	38	127.0	17.5	65.0	98.5	22.3	1.5	73.1	49.5	22.3	15.7	4	1.5	1/2	13	70	85	65
2"	50	152.4	19.0	77.7	120.6	25.4	1.5	91.9	61.9	25.4	19.0	4	2.3	5/8	16	85	95	70
2 1/2"	63	177.8	22.3	90.4	139.7	28.4	1.5	104.6	74.6	28.4	19.0	4	3.7	5/8	16	90	100	75
3"	75	190.5	23.8	107.9	152.4	30.2	1.5	127.0	90.6	30.2	19.0	4	4.2	5/8	16	90	100	75
4"	100	228.6	23.8	134.8	190.5	33.2	1.5	157.2	103.3	33.2	19.0	8	5.9	5/8	16	90	100	75
5"	125	254.0	23.8	163.5	215.9	36.5	1.5	185.6	116.0	36.5	22.3	8	7.0	3/4	19	95	110	85
6"	150	279.4	25.4	192.0	241.3	39.6	1.5	215.9	143.7	39.6	22.3	8	8.4	3/4	19	100	115	85
8"	200	342.9	28.4	246.1	298.4	44.4	1.5	269.7	170.6	44.4	22.3	8	13.0	3/4	19	110	120	90
10"	250	406.4	30.2	304.8	361.9	49.2	1.5	323.8	221.4	49.2	25.4	12	17.8	7/8	22.5	115	125	100
12"	300	482.6	31.7	365.2	431.8	55.6	1.5	381.0	276.3	55.6	25.4	12	29.5	7/8	22.5	120	135	100
14"	350	533.4	35.0	400.0	476.2	57.1	1.5	412.7	327.1	57.1	28.4	12	39.0	1	25.5	135	145	115
16"	400	596.9	36.5	457.2	539.7	63.5	1.5	469.9	359.1	63.5	28.4	16	42.0	1	25.5	135	145	115
18"	450	635.0	39.6	504.9	577.8	68.3	1.5	533.4	410.4	68.3	31.7	16	54.0	1 1/8	28.5	145	160	125
20"	500	698.5	42.9	558.8	635.0	73.1	1.5	584.2	461.7	73.1	31.7	20	68.0	1 1/8	28.5	160	170	140
24"	600	812.8	47.7	663.4	749.3	82.5	1.5	692.1	513.0	82.5	35.0	20	93.0	1 1/4	32	170	185	150

Nota 1: El largo de los hilo corrido no incluye el alto de los puntos.

* Fotos y datos referenciales. No aceptamos responsabilidad por usos incorrectos o mal interpretaciones de estos datos.

RANGOS DE PRESIÓN Y TEMPERATURA PARA CLASES ANSI/ASME B16.5

PRESIÓN DE TRABAJO (PSI)

TEMPERATURA		CLASES			
°C	°F	150	300	600	900
< 38	< 100	285	740	1480	2220
93	200	260	680	1360	2035
149	300	230	655	1310	1965
204	400	200	635	1265	1900
260	500	170	605	1205	1810
316	600	140	570	1135	1705
343	650	125	550	1100	1650
371	700	110	530	1060	1590
399	750	95	505	1015	1520
427	800	80	410	825	1235
454	850	65	320	640	955
482	900	50	230	460	690
510	950	35	135	275	410
538	1000	20	85	170	255

* Fotos y datos referenciales. No aceptamos responsabilidad por usos incorrectos o mal interpretaciones de estos datos.