



JIANZHI



* Foto Referencial

Material: Fierro Maleable Negro ASTM A197
 Estándar Americano: Clase 150
 Dimensiones: ASME B16.3
 Roscado: NPT ASME B1.20.1
 Galvanizado: ASTM A153 / HOT-DIP
 Certificación: UL / FM
 Usos: Aceites, petróleos, gases (GLP/ GNV), vapor y sistema contra incendio. No recomendado para químicos o productos similares.

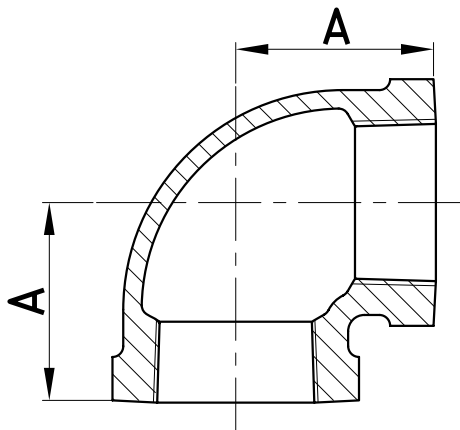

Medida		Dimensiones (mm)
inch	mm	A
1/8	6	17.5
1/4	8	20.6
3/8	10	24.1
1/2	15	28.5
3/4	20	33.3
1	25	38.1
1 1/4	32	44.5
1 1/2	40	49.3
2	50	57.2
2 1/2	65	68.6
3	80	78.2
3 1/2	90	86.9
4	100	96.3
5	125	114.3
6	150	130.3

* Nota : Dimensiones, diseño y materiales están sujetos a cambio sin previo aviso.

MAC - MMXXIV

