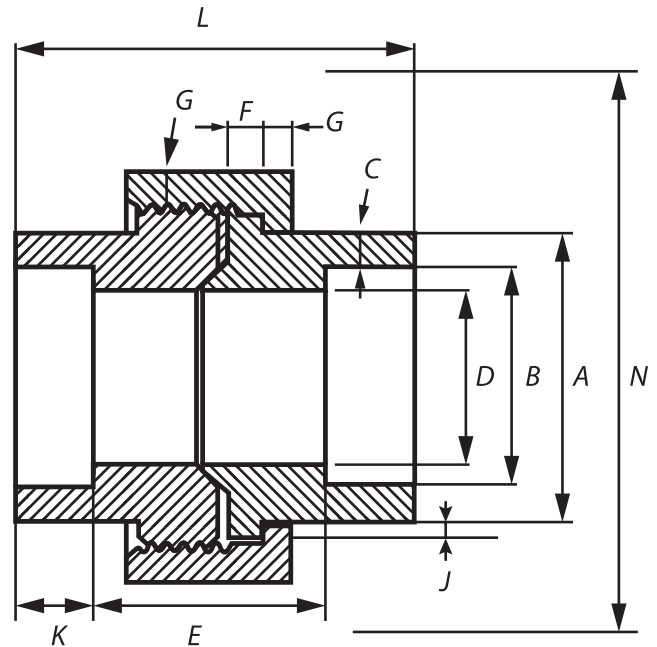

Normas de Diseño:

ASME B16.11

Material: Acero Inoxidable ASTM A182
316-316L

Presión de Trabajo: 3000 PSIG

Unidad: Milímetros (mm)

Medida		Final de Tubo	Dia. de Agujero Socket	Pared	Dia. Paso de Agua	Largo de Espacio	Brida Macho	Tuerca	Soporte	Fondo de Socket	Lago de Montaje Nom.	Limpieza Tuerca Montaje
pulg	mm	Min. A	B	Min. C	D	E	Min. F	Min. G	Min. J	Min. K	L	N
1/8"	6	21.8	11.18 10.67	3.18	7.59 6.07	22.4 19.1	3.18	3.18	1.24	9.7	41.4	50.8
1/4"	8	21.8	14.61 14.10	3.30	10.01 8.48	22.4 19.1	3.18	3.18	1.24	9.7	41.4	50.8
3/8"	10	25.9	18.03 17.53	3.51	13.28 11.76	26.9 20.6	3.43	3.43	1.37	9.7	46.0	55.9
1/2"	15	31.2	22.23 21.73	4.09	16.56 15.04	26.9 20.6	3.68	3.68	1.50	9.7	49.0	58.4
3/4"	20	37.1	27.56 27.05	4.27	21.69 20.17	31.8 25.4	4.06	4.06	1.68	12.7	56.9	66.0
1"	25	45.5	34.29 33.78	4.98	27.41 25.88	34.3 26.2	4.57	4.45	1.85	12.7	62.0	78.7
1 1/4"	32	54.9	43.05 42.55	5.28	35.81 34.29	40.6 32.5	5.33	5.21	2.13	12.7	71.1	94.0
1 1/2"	40	61.5	49.15 48.64	5.54	41.66 40.13	42.2 34.0	5.84	5.59	2.31	12.7	76.5	111.8
2"	50	75.2	61.62 61.11	6.05	53.26 51.74	45.5 37.3	6.60	6.35	2.69	15.7	86.1	132.1
2 1/2"	65	91.7	74.45 73.81	7.67	64.24 61.19	61.7 52.1	7.49	7.11	3.07	15.7	102.4	149.9
3"	80	109.2	90.42 89.79	8.31	79.45 76.40	63.8 53.6	8.26	8.00	3.53	15.7	109.0	175.3

(1) Valores superior e inferior para cada medida son respectivos al máximo y mínimo de dimensiones

* Fotos y medidas referenciales, sujetas a cambios sin previo aviso por parte del proveedor o fabricante, pero cumplen las normas bajo las cuales han sido fabricadas.