



# TEE NPT 6000 PSIG

## Normas de Diseño:

Roscado NPT ANSI B1.20.1

ASME B16.11

**Material:** Acero Forjado ASTM A105

Presión de Trabajo: 6000 PSIG

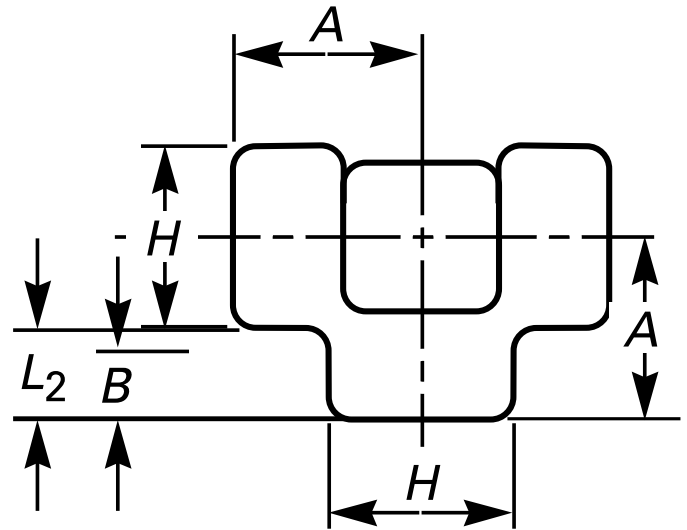

Unidad: Milímetros (mm)

Medida		Centro a Externo A	Diámetro Exterior de Banda H	Mínimo Espesor de Pared	Largo de Roscado min.	
pulg	mm				B	L2
1/8"	6	25	25	6.35	6.4	6.7
1/4"	8	28	33	6.60	8.1	10.2
3/8"	10	33	38	6.98	9.1	10.4
1/2"	15	38	46	8.15	10.9	13.6
3/4"	20	44	56	8.53	12.7	13.9
1"	25	51	62	9.93	14.7	17.3
1 1/4"	32	60	75	10.59	17.0	18.0
1 1/2"	40	64	84	11.07	17.8	18.4
2"	50	83	102	12.09	19.0	19.2
2 1/2"	65	95	121	15.29	23.6	28.9
3"	80	106	146	16.64	25.9	30.5
4"	100	114	152	18.67	27.7	33.0