

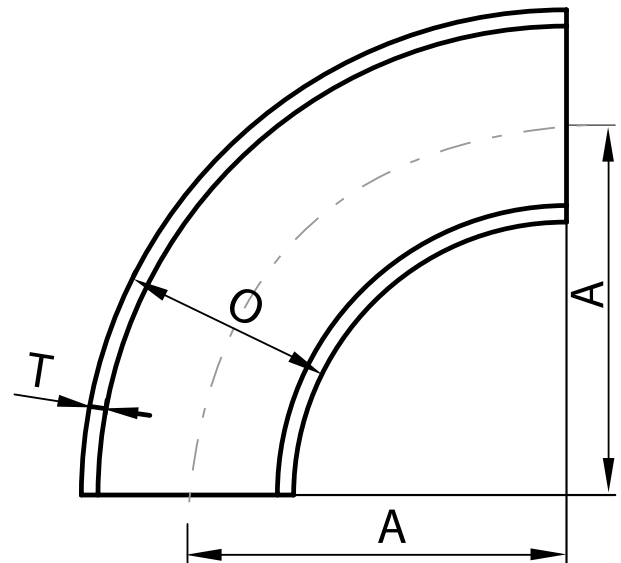

FEATURES DESIGN

Material SS 304 or 316L
 Polish 320G (I&O)
 SMS
 ASTM A270
 Grade Sanitary



DIMENSIONS

SIZE		A		O		T (wall thickness)
inch	mm	inch	mm	inch	mm	mm
1	25	1.500	38.1	1.000	25	1.5
1 1/4	32	1.875	47.63	1.250	32	1.5
1 1/2	38	2.250	57.15	1.500	38	1.5
2	51	3.000	76.2	2.000	51	1.5
2 1/2	25	3.750	95.25	2.500	25	1.5
3	76	4.500	114.3	3.000	76	1.5
4	102	6.000	152.4	4.000	102	1.5