

## D52

### Bronze Globe Valve

PN64

#### Features & Benefits

- Crane bronze globe valves are highly efficient for throttling because seat and disc designs provide flow characteristics with proportionate relationships between valve lift and flow rate.
- This valve features a renewable nickel alloy plug disc and a stainless steel seat.

#### Materials

NO.	PART	MATERIAL	SIZES
1	Body	Bronze BS EN 1982 CC491K	All
2	Bonnet	Bronze BS EN 1982 CC491K	All
3	Stem	Aluminium Bronze NES 834 Pt.2	All
4	Disc	Duplex Stainless Steel S32205	All
5	Union Ring	Bronze BS EN 1982 CC491K	All
5	Disc Holder	Brass BS EN 12165 CW617N	1/2 - 1
6	Packing	Asbestos Free	All
7	Gland	Brass BS EN 12164 CW614N	All
8	Packing Nut	Bronze BS EN 1982 CC491K	1 1/2 & 2
8	Packing Nut	Brass BS EN 12164 CW614N	1/2 - 1 1/4
9	Body Seat Ring	13% Cr.Steel BS 970 Pt.1 410S21	All
10	Disc Stem Ring	Aluminium Bronze NES 834 Pt.2	All
11	Disc Retaining Unit	Brass BS EN 12164 CW614N	1/2 - 2
11	Lockwasher	Brass BS EN 1652 CuZn 40Pb	All
12	Handwheel	Aluminium	1/2 - 1 1/2
12	Handwheel	Malleable Iron BS EN 1562 GJMB-300-6	2" only
13	Handwheel Nut	Brass BS EN 12164 CW614N	All
14	ID Plate	Aluminium	All

#### Dimensions & Weights

SIZE (inch)	WEIGHT (kg)	A (mm)	B (mm)	C (mm)
1/4	1	75	134	70
3/4	1.51	89	159	78
1	2.25	105	177	92
1 1/4	3.59	121	200	103
1 1/2	5.05	133	228	121
2	8.5	162	262	152



#### Dimensional Drawing

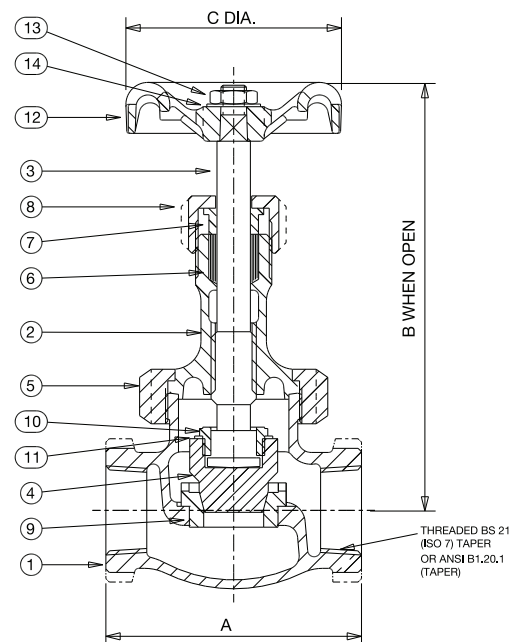

**PRESSURE RATING:** PN64

**TEMPERATURE OPERATING RANGE:** -10 to 288°C

**UK END CONNECTION:** BS 21 Taper

**US END CONNECTION:** Not Specified

**OPERATOR:** Handwheel

**AVAILABLE OPTOINS:** P150 Locking Device

**SPECIFICATION:** Valves having PN64 ratings are not specified in BS 5154.

D52 valves meet the requirements of BS 5154 in respect to materials design and method of manufacture as far as applicable.

Design incorporates a Duplex Stainless Steel S32205 plug type disc retained on the stem by a threaded ring. The body seat is a screwed-in stainless steel ring.

Valves having ANSI threads also generally conform to MSS SP-80.

Not suitable for use on unstable fluids as defined by the Pressure Equipment Directive 97/23/EC.