



\* Reference photo

Steel Body type ASTM A216 WCB  
 Ball: SS 316 (Optional SS 304)  
 Seats of RPTFE  
 Thread ends NPT ANSI/ASME B1.20.1  
 Memoryseal seating technology  
 Two pieces body. Full Passage.  
 Blow-Out-Proof Stem.  
 Maximum Working Pressure:  
 1/4" - 1" 2000 PSIG  
 1 1/4" - 4" 1500 PSIG  
 Maximum temperature operation:  
 RPTFE -20°C (-4°F) to 150°C (302°F)  
 Tests according to API 598

**MATERIALS**

	PART NAME	MATERIAL
1	BODY	WCB
2	BALL	ASTM A351 CF8M
3	SEAT	RPTFE
4	GASKET	PTFE
5	CAP	WCB
6	STEM	A276 - 316
7	THRUST WASHER	PTFE
8	ANTI-STATIC	SS304
9	HANDLE	SS+PVC
10	POSITION LOCATOR	Q235
11	NUTS	A194 2H
12	BELLEVILLE WASHER	SS301
13	PACKING GLAND	A276 304
14	PACKING	PTFE
15	STOPPER	A193 B7

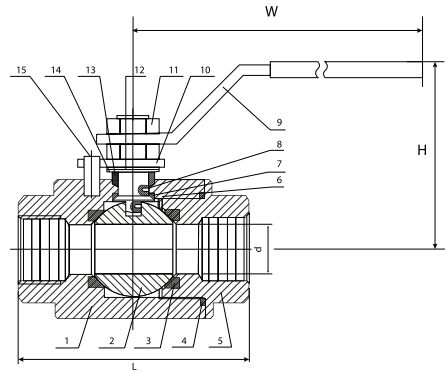

**Speed Logística y Servicios S.A.C.**  
 Importador y distribuidor autorizado de  
 válvulas REX para Perú y para su exportación.

**PRESSURE TEMPERATURE RATINGS**

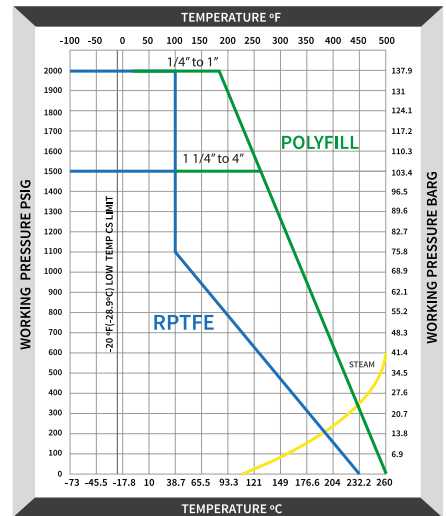

\* Note : Dimensions, design and materials are subject to change without notice. Approximate weights.

MAC EDITIONS - MMXXIII

