



* Reference photo

Body of Cast Iron ASTM A126
 Designed in accordance with MSS SP 67 and API 609
 Flange Connections: ANSI B16.5 RF class 150
 Tested according Section 5 AWWA c-504-87
 Mounting actuator ISO 5211 adaptable
 Disk stainless steel CF8M (316)
 Seat elastomeric: EPDM
 Maximum working pressure: 200 PSIG size 2" - 12" / 150 PSIG size 14" - 24"
 Maximum temperature operation: EPDM -18°C (0°F) to 110°C (230°F)
 Memoryseal seating technology
 Operation Lever or Gearbox
 Square shaft for mounting Lever or Gearbox
 Hidrostatic test API 598
 NOTE: Soft seated valves are not recommended for steam service, hot and abrasive fluids.
 * Certification pending to norms API 609, MSS SP-67 and Section 5 AWWA c-504-87.

MATERIALS

	PART NAME	MATERIAL
1	STEM	SS410
2	BUSHING	PTFE
3	O-RING	EPDM
4	PIN	SS316
5	DISK	CF8M
6	SEAT	EPDM
7	BODY	CAST IRON A126
8	KEY	CARBON STEEL

DIMENSIONS (mm)

SIZE	A	B	C	D	E	F	G	N	LEVER (Kg)	GEARBOX (Kg)
2"	162	83	43	31.8	12.7	6.7	57.2	102	2.66	7.56
2 1/2"	175	95	46	31.8	12.7	6.7	57.2	121	3.16	7.70
3"	181	102	46	31.8	12.7	6.7	57.2	130	3.68	8.25
4"	200	124	52	31.8	15.9	10.3	69.8	171	5.65	10.25
5"	213	137	56	31.8	19.0	10.3	69.8	197	7.26	12.20
6"	225	149	56	31.8	19.0	10.3	69.8	219	8.30	12.95
8"	260	181	60	44.4	22.2	14.3	88.9	268	13.67	22.68
10"	292	210	68	44.4	28.6	14.3	88.9	332	20.20	32.00
12"	337	248	78	44.4	31.8	14.3	108.0	406	37.08	45
14"	368	267	80	45	31.8	14.3	108.0	476	-	57
16"	400	298	90	51	33.34	20.6	158.75	539	-	96
18"	422	318	109	51	38	20.6	158.75	577	-	116
20"	479	349	135	64	41.15	20.6	158.75	635	-	161
24"	562	410	156	70	50.65	22	215.9	749	-	257

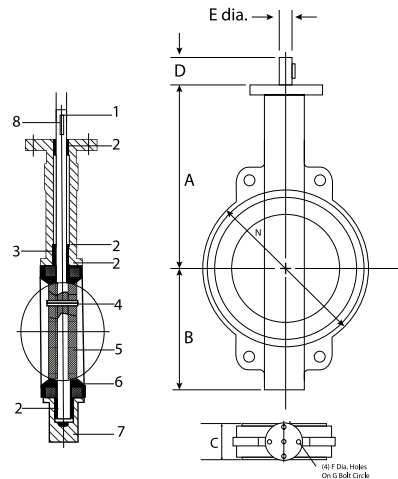

Speed Logística y Servicios S.A.C.
 Importador y distribuidor autorizado de válvulas REX para Perú y para su exportación.

* Note : Dimensions, design and materials are subject to change without notice. Approximate weights.

MAC EDITIONS - MMXXIII

