



* Reference photo

Body of Cast Iron ASTM A126
 Designed in accordance with MSS SP 67 and API 609
 Flange Connections:
 ANSI B16.5 RF class 150
 Tested according Section 5 AWWA c-504-87
 Mounting actuator ISO 5211 adaptable
 Disk stainless steel CF8M (316)
 Seat elastomeric: RPTFE
 Maximum working pressure:
 200 PSIG size 2" - 12"
 150 PSIG size 14" - 24"
 Maximum temperature operation:
 RPTFE -20°C (-4°F) to 150°C (302°F)
 Memoryseal seating technology
 Operation Lever or Gearbox
 Square shaft for mounting Lever or Gearbox
 Hidrostatic test API 598
 NOTE: Soft seated valves are not recommended for steam service, hot and abrasive fluids.
 * Certification pending to norms API 609, MSS SP-67 and Section 5 AWWA c-504-87.

MATERIALS

	PART NAME	MATERIAL
1	STEM	SS410
2	BUSHING	PTFE
3	O-RING	PTFE
4	PIN	SS316
5	DISK	CF8M
6	SEAT	RPTFE
7	BODY	CAST IRON A126
8	KEY	CARBON STEEL

DIMENSIONS (mm)

SIZE	A	B	C	D	E	F	G	Nº HOLES ANSI	LEVER (Kg)	GEARBOX (Kg)
2"	162	76	45	31.8	12.7	6.7	57.2	4	4.20	9
2 1/2"	175	89	48	31.8	12.7	6.7	57.2	4	4.50	11
3"	181	95	49	31.8	12.7	6.7	57.2	4	4.87	11.5
4"	200	114	55	31.8	15.9	10.3	69.8	8	7.68	13
5"	213	127	58	31.8	19.0	10.3	69.8	8	9.10	14.5
6"	225	140	59	31.8	19.0	10.3	69.8	8	12.62	16
8"	260	177	64	44.4	22.2	14.3	88.9	8	17.13	27
10"	292	203	70	44.4	28.6	14.3	88.9	12	28.40	38
12"	337	242	80	44.4	31.8	14.3	107.95	12	50.35	59
14"	368	267	80	45	31.8	14.3	107.95	12	-	70
16"	400	298	90	51	33.34	20.6	158.75	16	-	112
18"	422	318	109	51	38	20.6	158.75	16	-	134
20"	479	349	135	64	41.15	20.6	158.75	20	-	222
24"	562	410	156	70	50.65	22	215.9	20	-	310

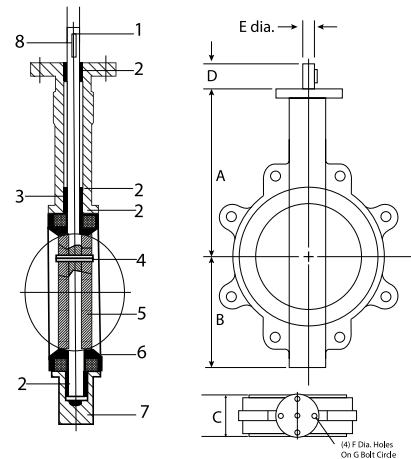

Speed Logística y Servicios S.A.C.
 Importador y distribuidor autorizado de
 válvulas REX para Perú y para su exportación.

* Note : Dimensions, design and materials are subject to change without notice. Approximate weights.

MAC EDITIONS - MMXXIII

