



\* Reference photo

Body of Ductile Iron ASTM A536  
 Designed and Face to Face API 609  
 Flange Connections:  
 ANSI B16.5 RF class 150  
 Mounting actuator ISO 5211 adaptable  
 Disk stainless steel CF8M (316)  
 Seat elastometric: EPDM  
 Maximum working pressure: 200 PSIG  
 Maximum temperature operation:  
 EPDM -18°C (0°F) to 110°C (230°F)  
 Memoryseal seating technology  
 Operation Lever or Gearbox  
 Square shaft for mounting Lever or Gearbox  
 Hidrostatic test API 598  
 NOTE: Soft seated valves are not recommended for steam service, hot and abrasive fluids.  
 \* Certification pending to norm API 609 from American Petroleum Institute

### MATERIALS

	PART NAME	MATERIAL
1	STEM	STAINLESS STEELSS 410
2	BODY	DUCTILE IRON ASTM A536
3	DISK	CF8M
4	SEAT	EPDM
5	END CAP	DUCTILE IRON ASTM A536
6	BOLT	STEEL
7	TAPER PIN	SS 304
8	O-RING	EPDM
9	BUSHING	PTFE
10	KEY	CARBON STEEL

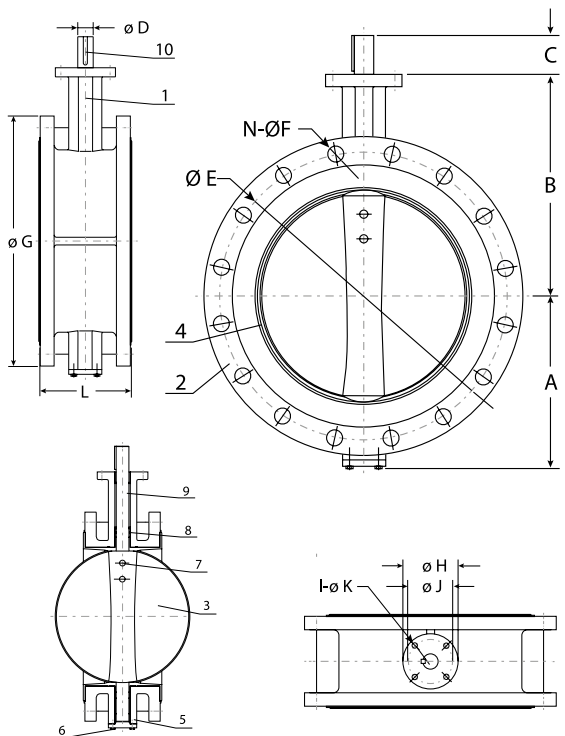

### DIMENSIONS (mm)

SIZE	A	B	C	D	E	N-F	G	H	J	I-K	L	Nº HOLES ANSI	WEIGHT (Kg)
2"	70	130	32	12.7	120.7	4-19	152	90	70	4-9.5	108	4	9.98
2 1/2"	75	140	32	12.7	139.7	4-19	178	90	70	4-9.5	112	4	10.88
3"	85	150	32	12.7	152.4	4-19	191	90	70	4-9.5	114	4	12.70
4"	104	160	32	15.9	190.5	8-19	229	90	70	4-9.5	127	8	15.87
5"	112	180	32	19.1	215.9	8-22	254	90	70	4-9.5	140	8	20.41
6"	130	200	32	19.1	241.3	8-22	279	90	70	4-9.5	140	8	26.76
8"	160	230	38	22.2	298.5	8-22	343	125	102	4-11.5	152	8	31.75
10"	194	260	38	28.6	362	12-25	406	125	102	4-11.5	165	12	59.86
12"	220	300	38	31.8	431.8	12-25	483	125	102	4-11.5	178	12	80.73

MAC EDITIONS - MMXXIII

**Speed Logística y Servicios S.A.C.**  
 Importador y distribuidor autorizado de  
 válvulas REX para Perú y para su exportación.

\* Note : Dimensions, design and materials are subject to change without notice. Approximate weights.

