



* Reference photo

Body and Bonnet Cast Iron ASTM A126
 Bolted Bonnet
 Rising Stem OS&Y
 Design, Manufacture, Test in accordance with MSS-SP-70
 Flange dimensions: ANSI/ASME B16.1
 Face to Face dimensions: ASME B16.10
 Hydrostatic Testing API 598
 Sizes from 16" with Gearbox

MATERIALS

	PART NAME	MATERIAL
1	BODY, BONET	ASTM A126B
2	SEAT RING	ASTM B62
3	WEDGE	ASTM A126B + ASTM B62
4	STEM	SS 410
5	BOLT/NUT	ASTM A307 -B
6	GASKET	GRAPHITE WITH SOFT STEEL
7	PACKING	GRAPHITE
8	STEM NUT	ASTM B62

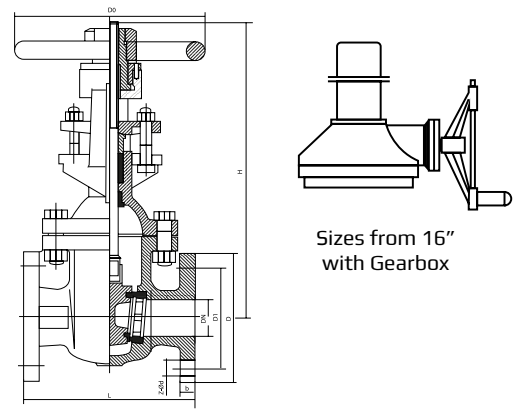

Sizes from 16" with Gearbox

DIMENSIONS (mm)

SIZE	L	D	D1	b	Z-Ød	D0	H	WEIGHT (Kg)
2"	178	152	121	16	4-19	200	320	19
2 1/2"	191	178	140	18	4-19	200	345	26
3"	203	191	152	19	4-19	200	387	29
4"	229	229	191	24	8-19	260	490	50
5"	254	254	216	24	8.22	300	576	71
6"	267	279	241	25.4	8-22	300	680	88
8"	292	343	298	29	8-22	350	808	136
10"	330	406	362	30.2	12-25	400	1010	214
12"	356	483	432	32	12-25	450	1080	294
14"	381	533	476	35	12-29	508	1640	450
16"	406	597	540	36.5	16-29	558	1804	580
18"	432	635	578	39.7	16-32	610	2090	760
20"	457	699	635	42.9	20-32	610	2490	935
24"	508	813	749	47.6	20-35	762	2960	1230

PRESSURE TEMPERATURE RATINGS (PSI)

Temperature °F/°C	Class 125	
	2" to 14"	14" to 24"
(-) 20 °F / (-) 29 °C to (+) 150 °F / (+) 66 °C	200	150
200 °F / 93 °C	190	135
225 °F / 107 °C	180	130
250 °F / 121 °C	175	125
275 °F / 135 °C	170	120
300 °F / 149 °C	165	110
325 °F / 163 °C	155	105
350 °F / 177 °C	150	100
375 °F / 191 °C	145	95
400 °F / 204 °C	140	90
425 °F / 218 °C	130	80
450 °F / 232 °C	125	75

* Note : Dimensions, design and materials are subject to change without notice. Approximate weights.

MAC EDITIONS - MMXXIII

