



* Reference photo

Body and Bonnet Cast Steel ASTM A216 WCB
 Bolted Bonnet. Rising Stem OS&Y.
 Design, Manufacture, Test in accordance with API 600.
 Norm Steel Valves: ANSI/ASME B16.34
 Flange dimensions: ANSI B16.5 RF
 Face to Face dimensions: ASME B16.10
 Hydrostatic Testing API 598

MATERIALS

	PART NAME	MATERIAL
1	SEAT RING	ASTM A216 WCB + 13% Cr
2	WEDGE	ASTM A216 WCB + 13% Cr
3	STEM	SS 410
4	STUD	ASTM A193 B7
5	NUT	ASTM A194 2H
6	GASKET	13Cr /GRAPH.
7	PACKING	GRAPHITE
8	STEM NUT	ASTM A439 D-2

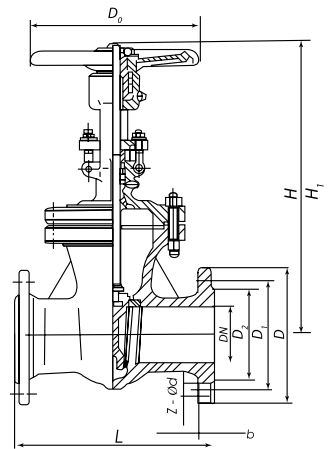

Speed Logística y Servicios S.A.C.
 Importador y distribuidor autorizado de
 válvulas REX para Perú y para su exportación.

DIMENSIONS (mm)

SIZE	L	D	D1	D2	b	Z-Ød	D0	H	H1	WEIGHT (Kg)
2"	216	165	127	92	23	8-19	250	356	416	22
2 1/2"	241	190	149	105	26	8-22	250	395	472	26
3"	283	210	168.5	127	29	8-22	300	440	528	45
4"	305	254	200	157	32	8-22	350	500	614	63
5"	381	279	235	186	35	8-22	350	550	639	80
6"	403	318	270	216	37	12-22	400	630	794	130
8"	419	381	330	270	42	12-25	500	850	1064	177
10"	457	445	387.5	324	48	16-29	600	1010	1264	284
12"	502	521	451	381	51	16-32	650	1160	1475	385
14"	762	584	514.5	413	54	20-32	650	1310	1662	820
16"	838	648	571.5	470	58	20-35	650	1545	1946	1010
18"	914	711	628.5	533	61	24-35	700	1623	2070	1350
20"	991	775	686	584	64	24-35	700	1770	2270	1740
24"	1143	914	813	692	70	24-41	800	2102	2710	2500

PRESSURE TEMPERATURE RATINGS (PSI)

Temperature °F/°C	Class 300
(-) 20 °F / (-) 29 °C to (+) 100 °F / (+) 38 °C	740
200 °F / 93 °C	675
300 °F / 149 °C	655
400 °F / 204 °C	635
500 °F / 260 °C	600
600 °F / 316 °C	550
650 °F / 343 °C	535
700 °F / 371 °C	535
750 °F / 399 °C	505
800 °F / 427 °C	410
850 °F / 454 °C	270
900 °F / 482 °C	170

* Note : Dimensions, design and materials are subject to change without notice. Approximate weights.

MAC EDITIONS - MMXXIII