



* Reference photo

Body and Bonnet Cast Steel ASTM A216 WCB
 Bolted Bonnet. Rising Stem OS&Y.
 Design, Manufacture, Test in accordance with API 600
 Norm Steel Valves: ANSI/ASME B16.34
 Flange dimensions: ANSI B16.5 RF
 Face to Face dimensions: ASME B16.10
 Hydrostatic Testing API 598

MATERIALS

	PART NAME	MATERIAL
1	BODY, BONNET	ASTM A216 WCB
2	SEAT RING	ASTM A216 WCB + 13% Cr
3	WEDGE	ASTM A216 WCB + 13% Cr
4	STEM	SS 410
5	STUD	AST A193 B7
6	NUT	ASTM A194 2H
7	GASKET	13Cr /GRAPH.
8	PACKING	GRAPHITE
9	STEM NUT	ASTM A439 D-2

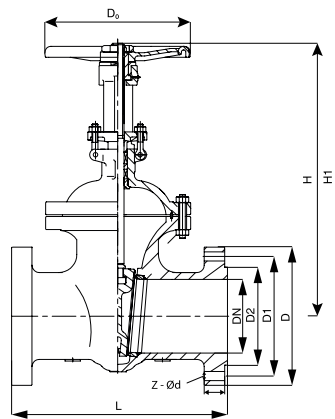

Speed Logística y Servicios S.A.C.
 Importador y distribuidor autorizado de
 válvulas REX para Perú y para su exportación.

DIMENSIONS (mm)

SIZE	L	D	D1	D2	b	Z-Ød	D0	H	H1	WEIGHT (Kg)
2"	292	165	127	92	26	8-19	250	408	469	32
2 1/2"	330	190	149	105	29	8-22	300	452	528	54
3"	356	210	168	127	32	8-22	300	504	592	77
4"	432	273	216	157	38	8-25	350	582	696	127
6"	559	356	292	216	48	12-29	450	765	929	267
8"	660	419	349	270	56	12-32	600	920	1134	489
10"	787	508	432	324	64	16-35	650	1050	1314	752
12"	838	559	489	381	67	20-35	700	1200	1512	938

PRESSURE TEMPERATURE RATINGS (PSI)

Temperature °F/°C	Class 600
(-) 20 °F / (-) 29 °C to (+) 100 °F / (+) 38 °C	1480
200 °F / 93 °C	1350
300 °F / 149 °C	1315
400 °F / 204 °C	1270
500 °F / 260 °C	1200
600 °F / 316 °C	1095
650 °F / 343 °C	1075
700 °F / 371 °C	1065
750 °F / 399 °C	1010
800 °F / 427 °C	825
850 °F / 454 °C	535
900 °F / 482 °C	345

* Note : Dimensions, design and materials are subject to change without notice. Approximate weights.

MAC EDITIONS - MMXXIII

