

DESIGN FEATURES:

Investment cast body & cap
Screwed-in cap
Connecting threads: NPT ANSI/ASME B1.20.1
Mesh 40
Test Standard: API 598

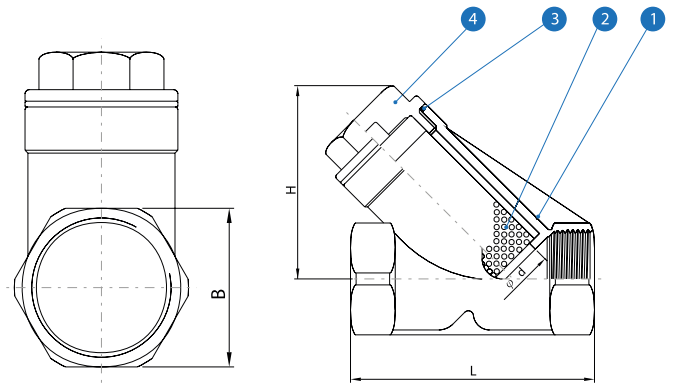

* Reference photo



MATERIAL LIST

	PART NAME	MATERIAL	QTY.
1	BODY	ASTM A351 Gr. CF8	1
2	SCREEN	SS316	1
3	GASKET	PTFE	1
4	CAP	ASTM A351 Gr. CF8	1

Speed Logística y Servicios S.A.C.
Importador y distribuidor
autorizado de válvulas SUN en
territorio latinoamericano.

DIMENSIONS (mm)

SIZE	d	B	H	L	WEIGHT (Kg)
1/4"	8	26	51	65	0.24
3/8"	10	26	51	65	0.23
1/2"	15	26	51	65	0.23
3/4"	20	33	60	80	0.36
1"	25	41	72	90	0.70
1 1/4"	32	49	77	105	0.90
1 1/2"	40	56	87	120	1.20
2"	50	69	103	140	1.90
2 1/2"	65	87	120	170	4.30
3"	80	102	140	200	6.30

PRESSURE TEMPERATURE RATINGS

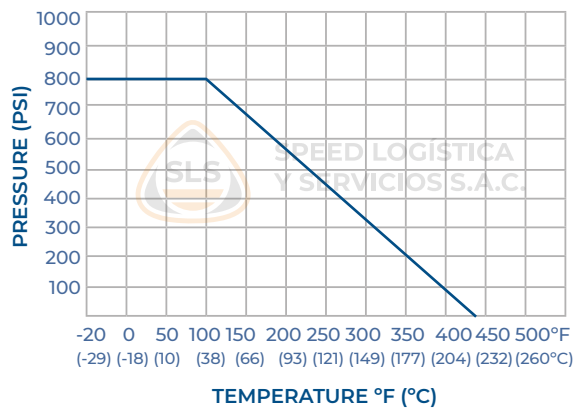

* Note : Dimensions, design and materials are subject to change without notice.

MAC - MMXXI