

**DESIGN FEATURES:**

Body: ASTM A351 Gr. CF8 (304)  
Screen: SS 304  
Gasket: PTFE  
Flange Dimensions: ANSI/ASME B16.5 150#  
Mesh 40  
Test standard: API 598

\* Reference photo

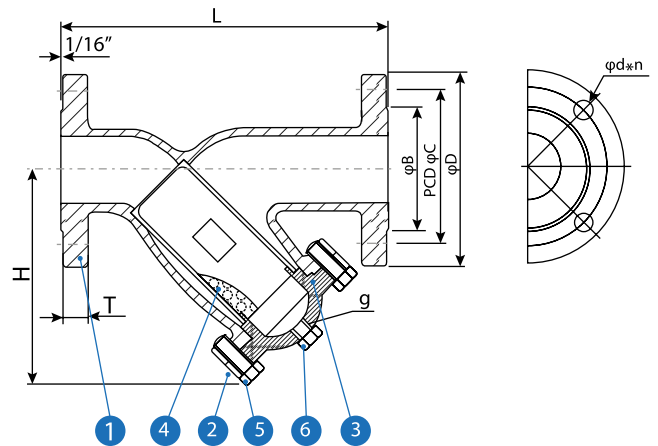

**MATERIAL LIST**

	PART NAME	MATERIAL	QTY.
1	BODY	ASTM A351 Gr. CF8	1
2	CAP	ASTM A351 Gr. CF8	1
3	GASKET	PTFE	1
4	SCREEN	SS304	1
5	BOLT	ASTM A193 B8	4-8
6	PLUG	SS304	1

Speed Logística y Servicios S.A.C.  
Importador y distribuidor  
autorizado de válvulas SUN en  
territorio latinoamericano.

**DIMENSIONS (mm)**

SIZE	B	C	D	d	H	L	n° of holes	T	G	CV Factor	WEIGHT (Kg)
2"	92	120.5	152	19	146	218	4	15.9	1/2"	500	13
2 1/2"	105	139.5	178	19	180	261	4	17.5	3/4"	850	23
3"	127	152.5	190	19	200	295	4	19.1	1"	1150	25
4"	157	190.5	229	19	240	361	8	23.9	1 1/2"	2120	33
6"	216	241.5	279	22	340	469	8	25.4	2"	5100	76
8"	-	-	343	-	397	495	8	-	2"	-	90
10"	-	-	406	-	470	622	12	-	2"	-	140
12"	-	-	483	-	566	718	12	-	2"	-	250

**PRESSURE TEMPERATURE RATINGS**

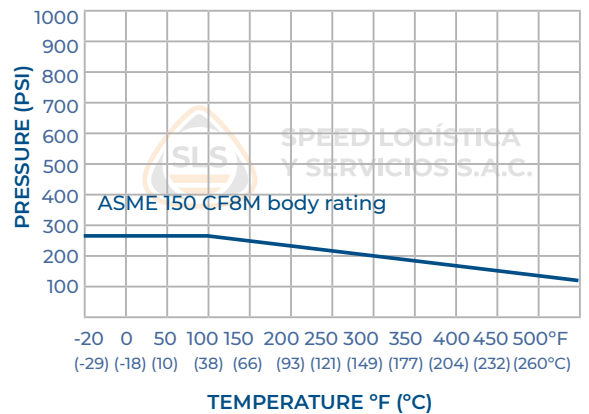

MAC - MMXXI

\* Note : Dimensions, design and materials are subject to change without notice.