

* Reference photo

DESIGN FEATURES:

Stainless Steel Body ASTM A351 CF8 (304)
 Seats of POLYFILL
 (PTFE + 15% de Graphite | Black)
 Thread ends NPT ANSI/ASME B1.20.1
 Featuring Memoryseal seating technology
 One piece body. Passage reduced.
 Test standard: API 598

MATERIAL LIST

PART NAME	MATERIAL
1 BODY	ASTM A351 CF8
2 RETAINER	ASTM A351 CF8
3 BALL	ASTM A351 CF8
4 STEM	ASTM A276-316
5 GLAND RING	ASTM A351 CF8
6 BALL SEAT	POLYFILL
7 THRUST WASHER	PTFE
8 PACKING	PTFE
9 SPRING WASHER	AISI 304
10 STEM NUT	AISI 304
11 HANDLE	STAINLESS STEEL
12 HANDLE SLEEVE	PVC

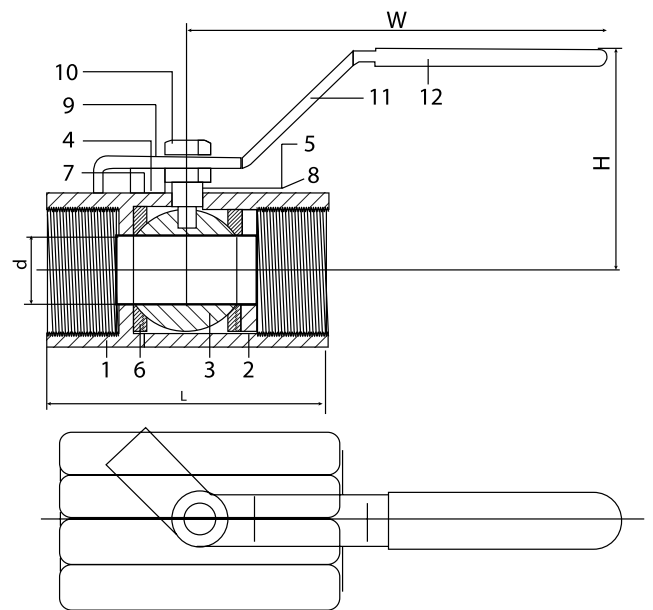

DIMENSIONS (mm)

SIZE	d	L	H	W	WEIGHT (Kg)
1/4"	5	43	28	2	0.2
3/8"	7	47	34	3.4	0.2
1/2"	9	62	60	4	0.8
3/4"	12	70	62	4	1.2
1"	15	86	67	5	1.8
1 1/4"	20	94	83	6	2.5
1 1/2"	25	102	83	6	3.5
2"	32	114	87	6	4.5

PRESSURE TEMPERATURE RATINGS

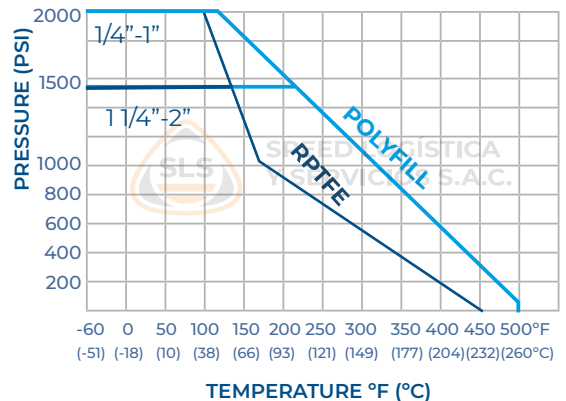

Speed Logística y Servicios S.A.C. Importador y distribuidor autorizado de válvulas SUN en territorio latinoamericano.

* Note : Dimensions, design and materials are subject to change without notice.

MAC - MMXXI