

* Reference photo

DESIGN FEATURES:

- Pressure rating: 1000 PSIG (non-shock)
- Steam rating: 150 PSI WSP
- Investment cast body
- Bottom-loaded, blow-out-proof stem
- Adjustable stem packing
- Stainless steel handle with vinyl grip
- Threaded end NPT ANSI/ASME B1.20.1
- Test standard: API 598



MATERIAL LIST

	PART NAME	MATERIAL	QTY.
1	BODY	ASTM A351 Gr. CF8	1
2	CAP	ASTM A351 Gr. CF8	1
3	BALL	ASTM A351 Gr. CF8	1
4	STEM	ASTM A276 Gr. 304	1
5	SEAT	RPTFE (PTFE + 15% G/F)	2
6	THRUST WASHER	PTFE	1
7	GLAND PACKING	PTFE	1
8	WASHER	SS304	2
9	SPRING WASHER	SS304	1
10	STEM NUT	SS304	1
11	HANDLE	STAINLESS STEEL	1
12	HANDLE SLEEVE	VINYL GRIP	1
13	LOCKING PLATE	STAINLESS STEEL	1

DIMENSIONS (mm)

SIZE	A	B	D	L	H	CV Factor	WEIGHT (Kg)
1/4"	5.0	60	17.0	39.0	31	1.0	0.08
3/8"	7.0	10	21.0	44.0	35	2.5	0.11
1/2"	9.2	86	25.0	56.0	43	5.5	0.17
3/4"	12.5	86	32.0	59.0	46	10.0	0.25
1"	16.0	104	38.0	71.0	50	15.5	0.45
1 1/4"	20.0	104	49.0	79.0	54	20.0	0.74
1 1/2"	24.5	126	53.0	83.0	65	37.0	0.83
2"	32.0	126	65.0	100.0	72	60.0	1.25

Speed Logística y Servicios S.A.C. Importador y distribuidor autorizado de válvulas SUN en territorio latinoamericano.

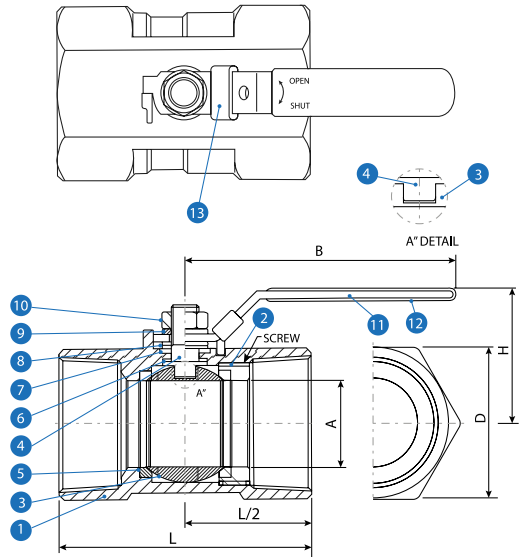

PRESSURE TEMPERATURE RATINGS

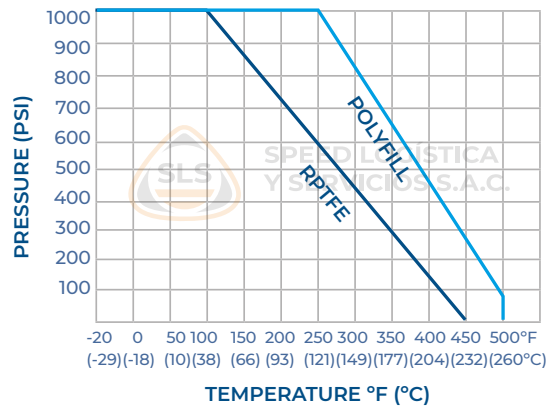

* Note : Dimensions, design and materials are subject to change without notice.

MAC - MMXXI