

\* Reference photo



## DESIGN FEATURES:

- Pressure Rating: PN25
- Steam Rating: 150 PSI WSP
- Investment Cast Body & Cap
- Bottom-Loaded, Blow-Out-Proof Stem Easy Actuator Mounting
- Stainless Steel Handle With Vinyl Grip Locking System
- Threaded End NPT ANSI/ASME B1.20.1
- Test standard: API 598

## MATERIAL LIST

	PART NAME	MATERIAL	QTY.
1	BODY	ASTM A351 Gr. CF8M	1
2	CAP	ASTM A351 Gr. CF8M	1
3	BALL	ASTM A351 Gr. CF8M	1
4	STEM	ASTM A276 Gr. 316	1
5	SEAT	RPTFE	2
6	GASKET	PTFE	1
7	THRUST WASHER	PTFE	1
8	PACKING	PTFE	1
9	GLAND	316	1
10	HANDLE	STAINLESS STEEL	1
11	HANDLE WASHER	SS304	1
12	HANDLE NUT	SS304	1
13	HANDLE SLEEVE	VINYL GRIP	1
14	LOCKING PLATE	STAINLESS STEEL	1

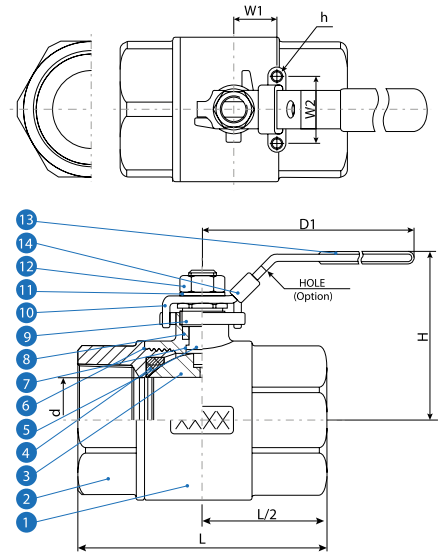

Speed Logística y Servicios S.A.C. Importador y distribuidor autorizado de válvulas SUN para Perú y su exportación.

## DIMENSIONS (mm)

SIZE	d	L	D1	H	W2	h	CV Factor	WEIGHT (Kg)
1/4"	11.0	59.5	100	53.5	36	M5XP0.8	6	0.207
3/8"	12.5	59.5	100	56.4	36	M5XP0.8	12	0.205
1/2"	15.0	64.0	102	55.0	36	M5XP0.8	19	0.231
3/4"	20.0	77.0	126	66.0	36	M5XP0.8	37	0.442
1"	25.0	90.8	126	71.0	36	M5XP0.8	64	0.597
1 1/4"	32.0	98.3	152	89.0	50	M6XP1.0	103	1.061
1 1/2"	38.0	117.5	152	92.0	50	M6XP1.0	143	1.500
2"	50.8	136.0	190	107.0	50	M6XP1.0	360	2.698
2 1/2"	65.0	165.0	190	119.0	70	M8XP1.25	440	4.757
3"	80.0	193.5	300	131.0	102	M10XP1.5	520	7.391
4"	100.0	216.0	380	171.0	102	M10XP1.5	650	15.500

\* Note : Dimensions, design and materials are subject to change without notice.

MAC - MMXXI