

\* Reference photo



## MATERIAL LIST

	PART NAME	MATERIAL	QTY.
1	BODY	ASTM A351 Gr. CF8M	1
2	CAP	ASTM A351 Gr. CF8M	2
3	BALL	ASTM A351 Gr. CF8M	1
4	STEM	ASTM A276 Gr. 316	1
5	SEAT	RPTFE (PTFE + 15% G/F)	2
6	PACKING	PTFE	1
7	GLAND	SS304	1
8	END SEALS	PTFE	2
9	THRUST WASHER	PTFE	1
10	HANDLE	STAINLESS STEEL	1
11	HANDLE NUT	SS304	1
12	SPRING WASHER	SS304	1
13	BOLTS	ASTM A193 Gr. B8	4-6
14	BOLT NUTS	ASTM 194 Gr. 8	4-6
15	BOLT WASHERS	SS304	4-6
16	HANDLE SLEEVE	VINYL GRIP	1
17	LOCKING PLATE	STAINLESS STEEL	1

## DIMENSIONS (mm)

SIZE	A	B	d	D1	L	H	W1	h	CV FACTOR	WEIGHT (Kg)
1/2"	65	95	15.0	102	130	57.0	36	M5 x P0.8	19	1.82
3/4"	75	105	20.0	126	150	67.1	36	M5 x P0.8	37	2.70
1"	85	115	25.4	126	160	76.0	36	M5 x P0.8	64	3.64
1 1/4"	100	140	32.0	156	180	91.1	50	M6 x P1.0	103	4.80
1 1/2"	110	150	40.0	156	200	95.1	50	M6 x P1.0	143	6.42
2"	125	165	50.8	186	230	105.0	50	M6 x P1.0	360	10.00
2 1/2"	145	185	65.0	272	290	120.8	70	M8 x P1.25	440	13.26
3"	160	200	80.0	272	310	127.4	102	M10 x P1.5	520	15.90
4"	190	235	100.0	335	350	173.7	102	M10 x P1.5	820	19.20

**Speed Logística y Servicios S.A.C. Importador y distribuidor autorizado de válvulas SUN en territorio latinoamericano.**

## DESIGN FEATURES:

- Working pressure: 285 PSIG
- Investment cast body & cap
- Flanged for ANSI/ASME B16.5 class 150 3PC Design
- Bottom-Loaded, Blow-Out-Proof Stem
- Stainless steel handle with vinyl grip
- Locking system
- Test standard: API 598
- Not recommend installing the valve with the stem pointing downward because dirt in the pipeline may then enter the body cavity and damage the gland packing.

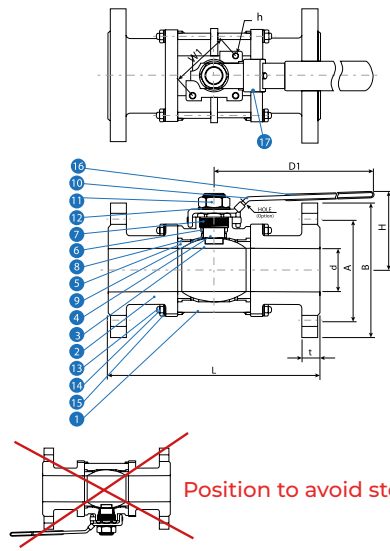

## PRESSURE TEMPERATURE RATINGS

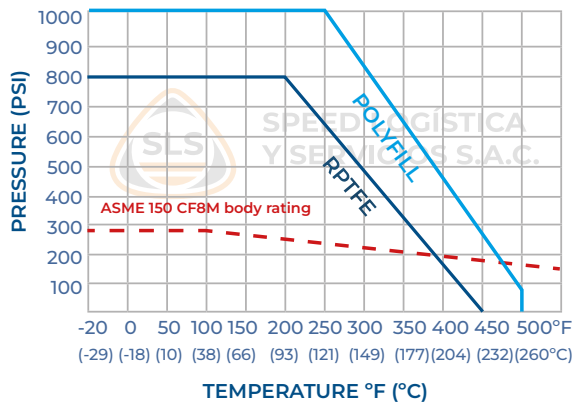

\* Note : Dimensions, design and materials are subject to change without notice.

MAC - MMXXI

Navigation icons: location pin, phone, WhatsApp, and email.

Navigation icons: location pin, phone, and email.