

* Reference photo

DESIGN FEATURES:

- Working pressure: 1000 PSIG
- Investment casting body & cap
- Low deformation under load
- Blow-out-proof stem
- Direct mounting of actuators with ISO 5211
- Threaded end NPT ANSI/ASME B1.20.1
- ANSI/ASME B16.34 full compliance
- Test standard: API 598

MATERIAL LIST

#	PART NAME	MATERIAL	QTY.
1	BODY	ASTM A351 Gr. CF8M	1
2	CAP	ASTM A351 Gr. CF8M	2
3	BALL	ASTM A351 Gr. CF8M	1
4	SEAT	RPTFE (PTFE + 15% G/F)	2
5	BOLT	ASTM A193 Gr. B8	4-6
6	GASKET	PTFE	2
7	THRUST WASHER	PTFE	1
8	STEM	ASTM A276 Gr. 316	1
9	PACKING	PTFE	1
10	RING	SS304	1
11	BELLEVEILLE WASHER	SS410	2
12	HANDLE NUT	SS304	2
13	STOPPER	SS304	1
14	LOCKING PLATE	STAINLESS STEEL	1
15	HANDLE	STAINLESS STEEL	1
16	HANDLE SLEEVE	VINYL GRIP	1
17	BOLT WASHER	SS304	4-6
18	BOLT NUT	ASTM A194 Gr. 8	4-6

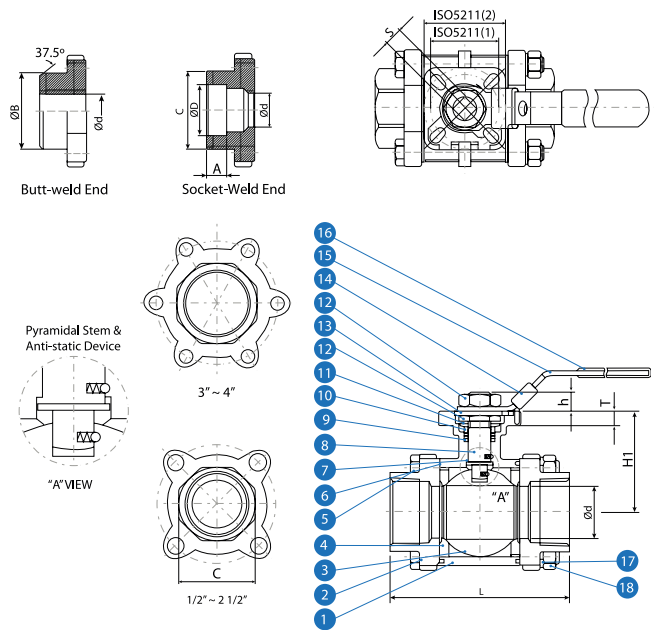

DIMENSIONS (mm)

SIZE	A	B	C	D	d	L	H1	h	S	T	ISO 5211	CV Factor	WEIGHT (Kg)
1/2"	10	22.5	26.8	21.7	15.0	71	42.1	9.0	9	9	F03/F04	26	0.78
3/4"	13	28.3	34.6	27.1	20.0	85	46.5	9.0	9	9	F03/F04	55	0.98
1"	13	35.0	39.5	33.8	25.4	95	59.0	11.5	11	9	F04/F05	110	1.43
1 1/4"	13	44.1	49.0	42.6	32.0	111	62.5	11.5	11	9	F04/F05	180	2.17
1 1/2"	13	50.0	55.8	48.7	40.0	121	79.0	16.0	14	13	F05/F07	270	3.28
2"	16	60.5	68.0	61.1	50.8	140	86.9	16.0	14	13	F05/F07	500	4.64
2 1/2"	16	77.8	88.0	73.8	65.0	173	111.0	19.0	17	13	F07/F10	800	9.63
3"	16	89.1	105.0	89.8	80.0	192	123.0	19.0	17	13	F07/F10	1150	15.50
4"	19	114.3	130.0	115.5	100.0	225	159.0	24.0	17	20	F07/F10	2120	23.78

PRESSURE TEMPERATURE RATINGS

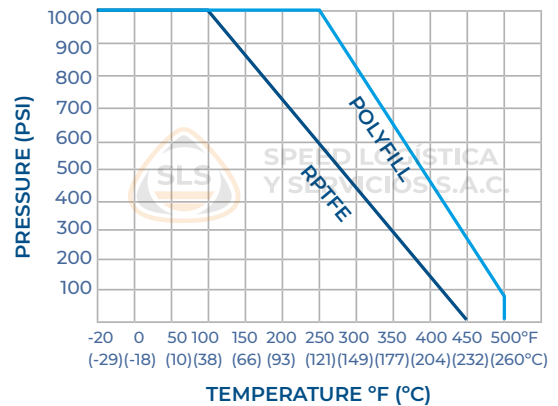

Speed Logística y Servicios S.A.C. Importador y distribuidor autorizado de válvulas SUN en territorio latinoamericano.

* Note : Dimensions, design and materials are subject to change without notice.

MAC - MMXXI