

* Reference photo

DESIGN FEATURES:

Steam rating: 150 PSI WSP
Blow-out-proof stem design
ISO 5211 actuator mounting pad
Working pressure: 1000 PSIG
Locking system
Threaded type: NPT ANSI/ASME B1.20.1
Test standard: API 598

MATERIAL LIST

	PART NAME	MATERIAL	QTY.
1	BODY	ASTM A351 Gr. CF8M	1
2	CAP 2	ASTM A351 Gr. CF8M	2
3	STEM	ASTM A276 Gr. 316	1
4	GLAND NUT	SS304	1
5	BALL	ASTM A351 Gr. CF8M	1
6	SEAT	RPTFE	4
7	THRUST WASHER	PTFE	1
8	PACKING	PTFE	1
9	JOINT GASKET	PTFE	2
10	STEM BOLT	SS304	1
11	WASHER	SS304	1
12	HANDLE	STAINLESS STEEL	1
13	STEM WASHER	SS304	1
14	SET SCREW	SS304	1
15	HANDLE SLEEVE	VINYL GRIP	1
16	SET BOLT	SS304	1
17	JOINT GASKET	PTFE	1
18	CAP 1	ASTM A351 Gr. CF8M	1

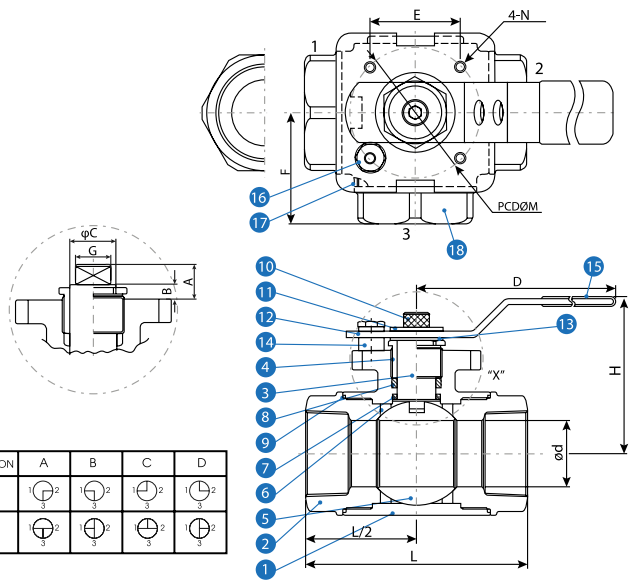

POSITION	A	B	C	D
L PORT				
T PORT				

DIMENSIONS (mm)

SIZE	A	B	C	G	d	L	H	D	E	F	M	N	CV Factor	WEIGHT (Kg)
1/4"	10.7	5.7	12.0	9.0	11.0	69.4	62.5	133.4	30.0	35.5	42	M5XP0.8	6	0.82
3/8"	10.7	5.7	12.0	9.0	11.0	69.4	62.5	133.4	30.0	35.5	42	M5XP0.8	6	0.78
1/2"	10.7	5.7	12.0	9.0	12.7	75.7	65.9	133.4	35.0	40.0	42	M5XP0.8	12	0.74
3/4"	10.9	3.9	15.0	11.0	16.0	86.6	84.9	178.5	35.0	42.0	50	M5XP1.0	16	1.18
1"	20.0	8.5	15.0	11.0	20.0	102.4	88.7	178.5	35.0	44.0	50	M5XP1.0	20	1.70
1 1/4"	23.4	7.9	15.0	11.0	25.0	118.2	83.9	209.9	35.0	46.0	50	M5XP1.0	37	2.82
1 1/2"	25.8	10.3	15.0	11.0	32.0	125.8	103.3	208.0	49.5	57.0	70	M5XP1.25	103	3.96
2"	25.3	9.8	18.5	14.0	38.1	149.0	111.5	229.9	50.0	64.0	70	M5XP1.25	143	6.78

PRESSURE TEMPERATURE RATINGS

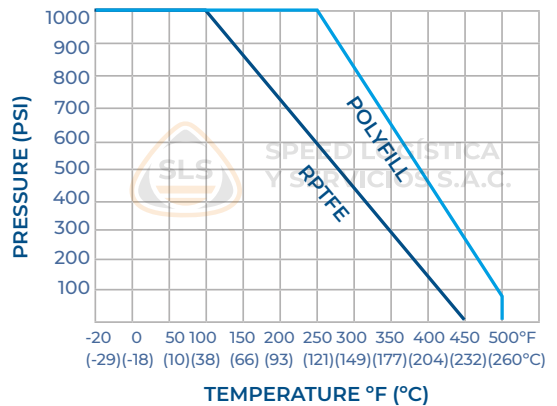

Speed Logística y Servicios S.A.C. Importador y distribuidor autorizado de válvulas SUN en territorio latinoamericano.

* Note : Dimensions, design and materials are subject to change without notice.

MAC - MMXXI

