

DESIGN FEATURES:

Rising stem
O.S. & yoke, flexible wedge
End type: flange end
Face to face: ANSI/ASME B16.5
Wall thickness: ANSI/ASME B16.34
Pressure/temperature ratings in accordance with ASME B16.34
Test standard: API 598

* Reference photo



MATERIAL LIST

	PART NAME	MATERIAL	QTY.
1	BODY	ASTM A351 Gr. CF8M	1
2	BONNET	ASTM A351 Gr. CF8M	1
3	STEM	ASTM 276 GR. 316	1
4	DISC	ASTM A351 Gr. CF8M	1
5	GLAND	ASTM A351 Gr. CF8	1
6	GLAND PACKING	PTFE	1
7	GLANDE FLANGE	ASTM A351 Gr. CF8	1
8	HAND WHEEL	ASTM A536 Gr.B65-45-12	1
9	GASKET	PTFE	1
10	BONNET BOLT/NUT	ASTM A 193 Gr. B8 / ASTM A194 Gr. 8	4-16
11	GLAND BOLT/NUT	ASTM A 193 Gr. B8 / ASTM A194 Gr. 8	2
12	YOKE SLEEVE	BRONZE	1
13	HAND WHEEL NUT	STEEL	1
14	YOKE SLEEVE NUT	SS304	1

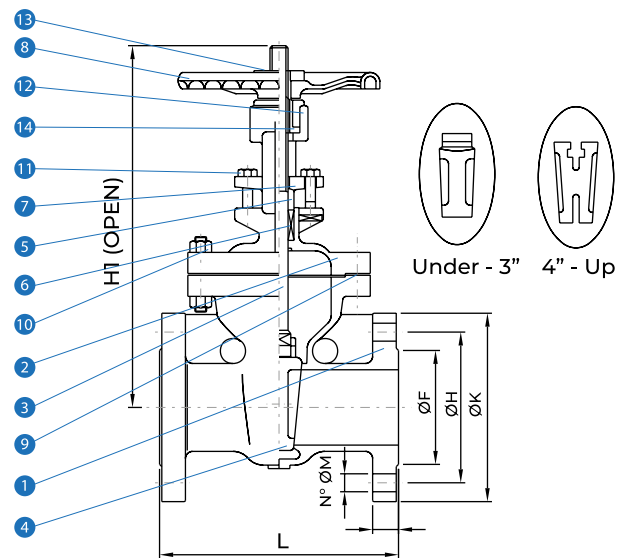

Speed Logística y Servicios S.A.C. Importador y distribuidor autorizado de válvulas SUN en territorio latinoamericano.

DIMENSIONS (mm)

SIZE	L	H1	K	H	F	T	M	N	CV FACTOR	WEIGHT (Kg)
1/2"	108	204	100	60.5	35	11.2	15.7	4	19	3.40
3/4"	117	209	100	70.0	43	11.2	15.7	4	36	4.50
1"	127	229	100	79.5	51	11.2	15.7	4	57	5.50
1 1/4"	140	270	117	89.0	64	14.3	15.7	4	100	6.50
1 1/2"	165	283	140	98.5	73	14.3	15.7	4	120	9.00
2"	178	332	160	120.5	92	15.9	19.0	4	140	11.50
2 1/2"	190	397	180	139.5	105	17.5	19.0	4	240	18.00
3"	203	439	200	152.5	127	19.1	19.0	4	360	20.00
4"	229	518	224	190.5	157	23.9	19.0	8	580	30.00
5"	254	621	250	216.5	186	23.9	22.3	8	950	44.00
6"	267	714	280	241.5	216	25.4	22.3	8	2400	56.00
8"	292	914	300	298.5	270	28.6	22.3	8	4200	82.00
10"	330	1108	355	362.0	324	30.2	25.4	12	6800	132.00
12"	356	1553	600	432.0	381	31.8	25.4	12	9900	196.50

MAC - MMXXI

* Note : Dimensions, design and materials are subject to change without notice.

