

DESIGN FEATURES:

Rising stem
O.S. & yoke, flexible wedge
End type: flange end
Face to face: ANSI/ASME B16.5
Wall thickness: ANSI/ASME B16.34
Pressure/temperature ratings in accordance with ASME B16.34
Test standard: API 598

* Reference photo

MATERIAL LIST

	PART NAME	MATERIAL	QTY.
1	BODY	ASTM A351 Gr. CF8M	1
2	BONNET	ASTM A351 Gr. CF8M	1
3	STEM	ASTM 276 Gr. 316	1
4	DISC	ASTM A351 Gr. CF8M	1
5	GLAND	ASTM A351 Gr. CF8	1
6	GLAND PACKING	PTFE	1
7	GLANDE FLANGE	ASTM A351 Gr. CF8	1
8	HAND WHEEL	ASTM A536 Gr.B65-45-12	1
9	GASKET	PTFE	1
10	BONNET BOLT/NUT	ASTM A 193 Gr. B8 / ASTM A194 Gr. 8	4-16
11	GLAND BOLT/NUT	ASTM A 193 Gr. B8 / ASTM A194 Gr. 8	2
12	YOKE SLEEVE	BRONZE	1
13	HAND WHEEL NUT	STEEL	1
14	YOKE SLEEVE NUT	SS304	1

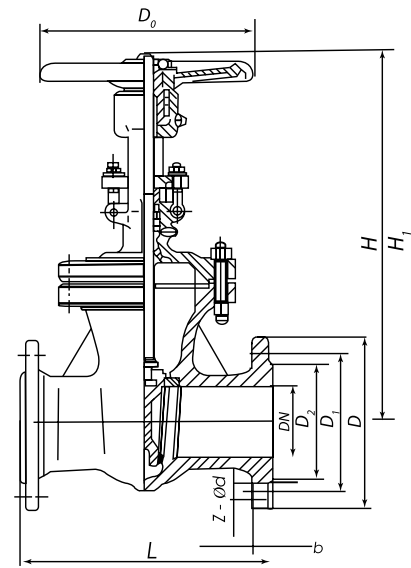

Speed Logística y Servicios S.A.C. Importador y distribuidor autorizado de válvulas SUN en territorio latinoamericano.

DIMENSIONS (mm)

SIZE	L	D	D1	D2	B	Z-Ød	D0	H	H1	WEIGHT (Kg)
2"	216	165	127	92	23	8-19	250	356	416	30
2 1/2"	241	190	149	105	26	8-22	250	395	472	33
3"	283	210	168.5	127	29	8-22	300	440	528	49
4"	305	254	200	157	32	8-22	350	500	614	73
6"	403	318	270	216	37	12-22	400	630	794	139
8"	419	381	330	270	42	12-25	500	850	1064	225
10"	457	445	387.5	324	48	16-29	600	1010	1264	343
12"	502	521	451	381	51	16-32	650	1160	1475	475

* Note : Dimensions, design and materials are subject to change without notice.

MAC - MMXXI