

\* Reference photo

## DESIGN FEATURES:

- Steam rating: 150 PSI WSP
- Blow-out-proof stem design
- ISO 5211 actuator mounting pad
- Multiport design
- Flange dimensions ANSI B16.5
- Test standard: API 598

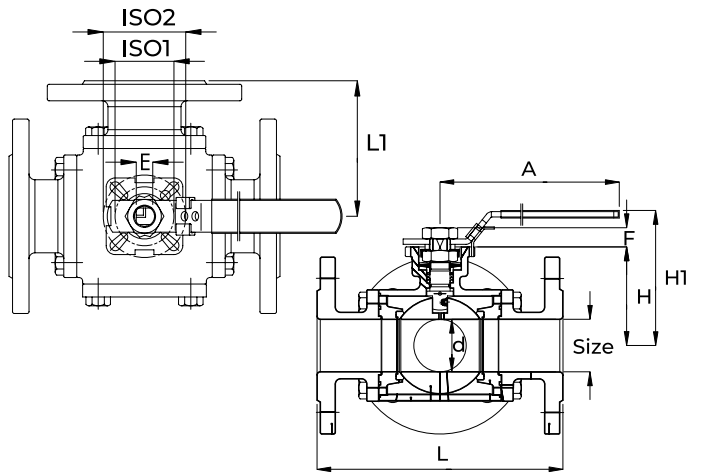

## MATERIAL LIST

	PART NAME	MATERIAL
1	BODY	CF8M
2	FLANGE CAP	CF8M
3	COVER	CF8M
4	BALL & STEM	SS316
5	BALL SEAT	PTFE
6	JOINT GASKET	PTFE
7	GASKET	PTFE
8	STEM PACKING	PTFE
9	GLAND	CF8
10	STOPPER	SS304
11	C RETAINER RING	SK7
12	BOLT	ASTM A193 B8
13	HANDLE	STAINLESS STEEL
14	BOLT	ASTM A193 B8
15	NUT	ASTM A194 8
16	SLEEVE	PTFE
17	STUD BOLD	ASTM A193 B8
18	NUT	ASTM A194 8

## DIMENSIONS (mm)

SIZE	d	L	L1	A	F	H	H1	E	ISO1	ISO2	WEIGHT (Kg)
1"	25	181	90	175	11	70	104	11	F04	F05	8.71
1/2"	38	212	106	200	14	87	120	14	F05	F07	14.42
2"	49	229	115	200	14	92	126	14	F05	F07	19.22
2 1/2"	63	290	145	265	17	107	155	17	F07	F10	31.74
3"	75	310	155	265	17	119	167	17	F07	F10	43.55
4"	99	367	183	400	22	150	214	22	F10	F10	64.48

**Speed Logística y Servicios S.A.C. Importador y distribuidor autorizado de válvulas SUN en territorio latinoamericano.**

### Ball Position

PORT	STANDARD		OPTIONAL	
	A	B	C	D
"T" PORT				

## PRESSURE TEMPERATURE RATINGS

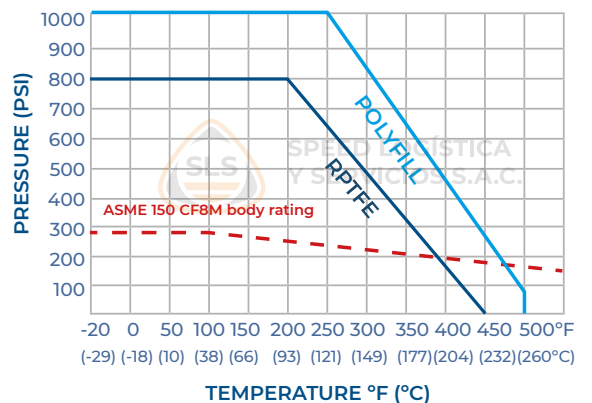

\* Note : Dimensions, design and materials are subject to change without notice.

MAC - MMXXI