

* Reference photo

DESIGN FEATURES:

Body and Bonnet CF3M
Fully Lugged
Full Port
Testing API 598

Service Recomendations
It has good resistance to organic acids and salts, sulphuric and sulphurous acids, phosphoric and phosphoric-sulphurichydro fluoric acid mixtures, sulphate and suphite liquors, sea water and other chloride solutions, sodium hydroxide and steam.



MATERIAL LIST

	PART NAME	MATERIAL
1	Disc	CF8M
2	Body / Bonnet	CF3M
3	Packing	PTFE
4	Glande Flange	CF8M
5	Nut	316
6	Stem	F316
7	Yoke	CF8M
8	Stem Nut	H62
9	Handwheel	QT400-47
10	Handwheel Nut	35
11	Seat	RPTFE

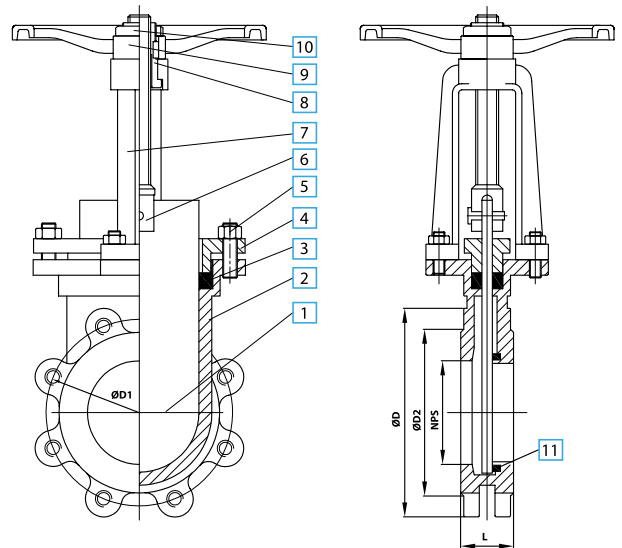

Speed Logística y Servicios S.A.C. Importador y distribuidor autorizado de válvulas SUN en territorio latinoamericano.

DIMENSIONS (mm)

SIZE	D	D1	D2	L	Nº HOLES ANSI	WEIGHT (Kg)
2"	152	120.5	92	48	4	8.92
2 1/2"	178	139.5	105	48	4	10.14
3"	190	152.5	127	51	4	10.16
4"	229	190.5	157	51	8	12.52
6"	279	241.5	216	57	8	22.22

* Note : Dimensions, design and materials are subject to change without notice.

MAC - MMXXI