



Check Swing Cast Steel A216 WCB Class 300

Body and Bonnet Cast Steel A216 WCB
 Bolted Bonnet
 Norm Steel Valves: ANSI/ASME B16.34
 Flange dimensions: ANSI/ASME B16.5 RF
 Face to Face dimensions: ANSI/ASME B16.10
 Hydrostatic Testing API 598
 Diameters: 2" to 20"

* Certification pending to norm API 600 from American Petroleum Institute

PRESSURE TEMPERATURE RATINGS

Temperature °F/°C	Pressure worked lbs/inch ² (PSI)
	Class 300
(-) 20 °F / (-) 29 °C to (+) 100 °F / (+) 38 °C	740
200 °F / 93 °C	675
300 °F / 149 °C	655
400 °F / 204 °C	635
500 °F / 260 °C	600
600 °F / 316 °C	550
650 °F / 343 °C	535
700 °F / 371 °C	535
750 °F / 399 °C	505
800 °F / 427 °C	410
850 °F / 454 °C	270
900 °F / 482 °C	170
950 °F / 510 °C	105
1000 °F / 538 °C	50



* Reference photo

* Note : Dimensions, design and materials are subject to change without notice.



Check Swing Cast Steel A216 WCB Class 300

MATERIALS

	PART NAME	MATERIAL
1	BODY BONNET	ASTM A216 WCB
2	SEAT RING	ASTM A216 WCB + 13% Cr
3	DISK	ASTM A216 WCB + 13% Cr
4	HINGE	ASTM A216 WCB
5	HINGE PIN	ASTM A276 420
6	STUD	ASTM A193 B7
7	NUT	ASTM A194 2H
8	GASKET	13Cr / GRAPH

TEST API 598

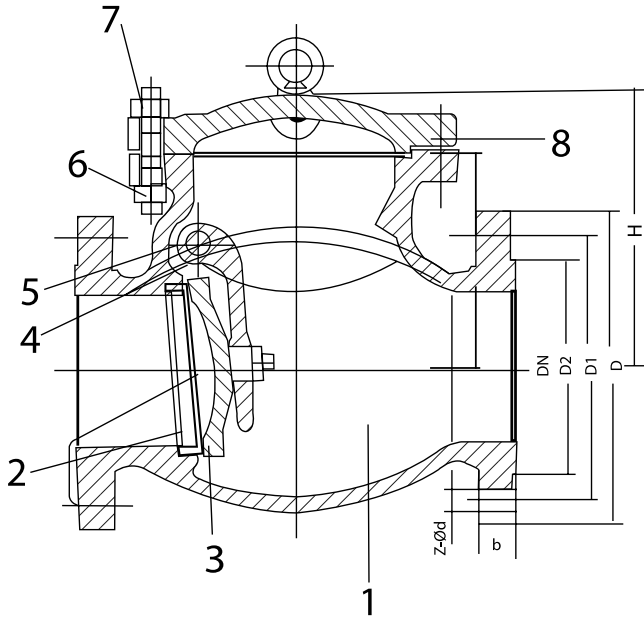

DIMENSIONS (mm)

SIZE	L	D	D ₁	D ₂	B	Z-φd	H	WEIGHT (KG)
2"	267	165	127	92	23	8-19	160	18
2 1/2"	292	190	149	105	26	8-22	172	28
3"	318	210	168.5	127	29	8-22	189	38
4"	356	254	200	157	32	8-22	210	67
6"	445	318	270	216	37	12-22	330	123
8"	533	381	330	270	42	12-25	418	207
10"	622	445	387.5	324	48	16-29	450	305
12"	711	521	451	381	51	19-32	508	387

* Note : Dimensions, design and materials are subject to change without notice.